

Purpose: Realization of abnormality diagnosis technology for power electronics equipment utilizing machine learning that does not require deep specialized knowledge or the addition of many measuring instruments with the aim of improving the continuity of operation of electric power and mobile equipment.

Conventional power system (None abnormality diagnosis)

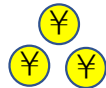

Future power system (with abnormality diagnosis)

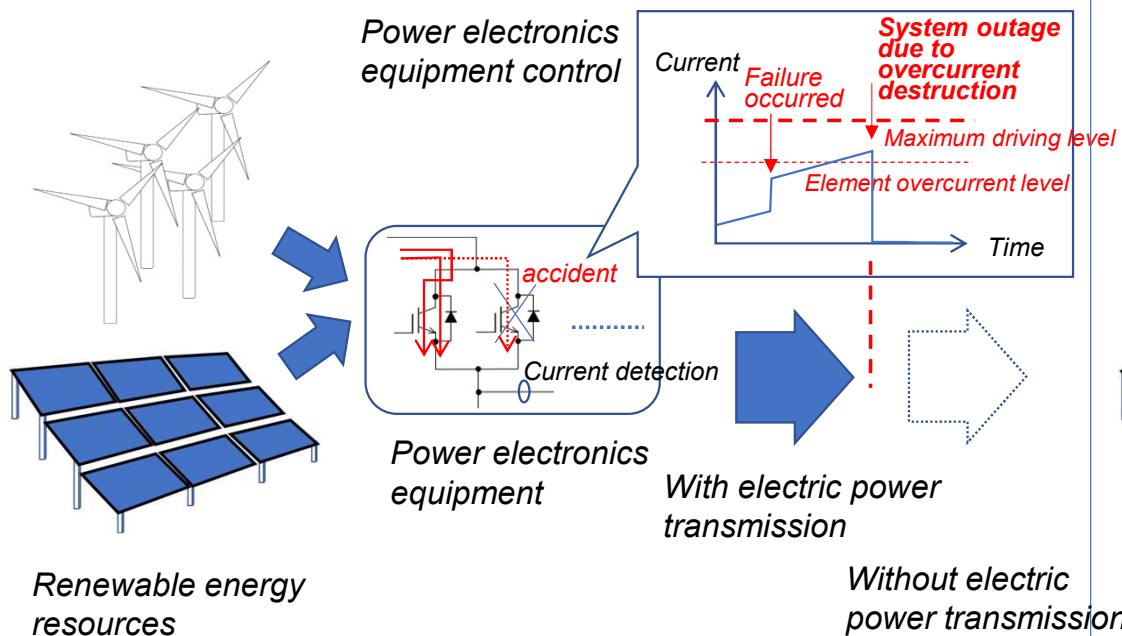
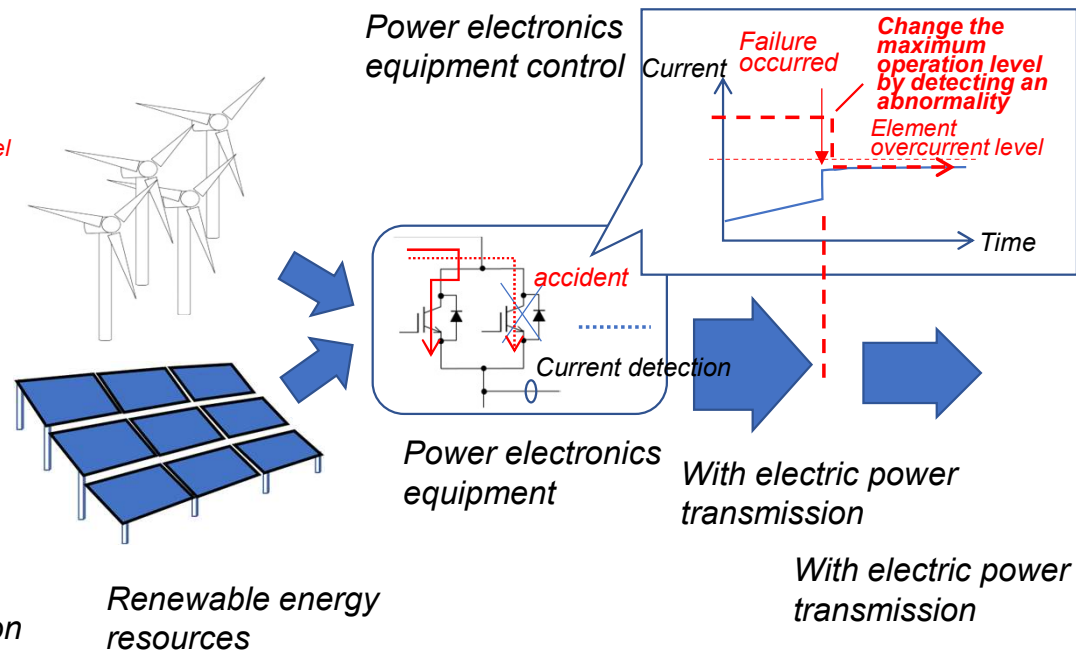

Advantages of abnormality diagnosis function + power electronics control

1. Using the machine learning method SVM, the diagnosis of abnormalities in DC/DC converter components is verified by simulation. Four states are identified using output voltage waveform data with time resolution of 80k~800kHz (5) and voltage resolution of 8~14bit (7).

(1) Verification conditions

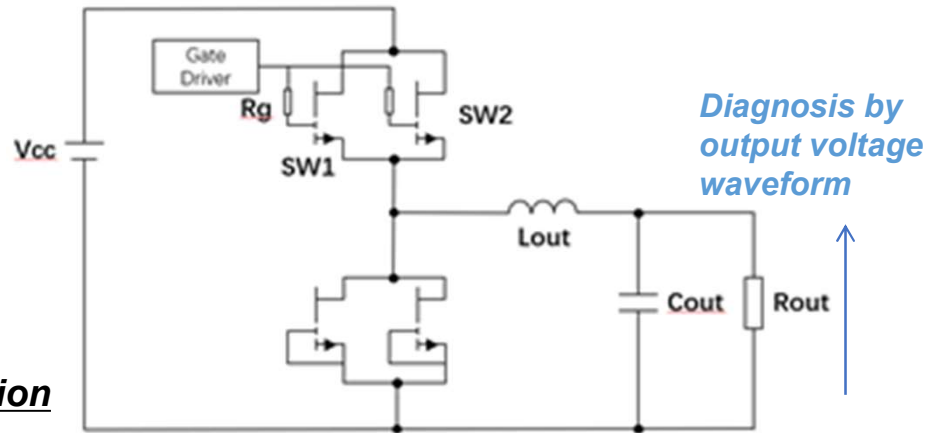

Figure 1. Circuit configuration

Table 1. Circuit parameters for the four states

	SW	Lout	Cout
All normal	SW1: Action SW2: Action	800 μ H \pm 5 %	0.47 μ F \pm 5 %
Only SW is abnormal	SW1: Action SW2: Stop	Normal	Normal
Only Lout is abnormal	Normal	800 μ H -50 % ~ -6 % +6 % ~ +10 %	Normal
Only Cout is abnormal	Normal	Normal	0.47 μ F -50 % ~ -6 % +6 % ~ +10 %

Table 2. Other circuit parameters

	Steady-state waveform	Transient state waveform
Vcc	400V \pm 5%	
SW1, SW2	GaN HEMT GS66516B model	
Rg	2 Ω \pm 5%	
Rout	20 Ω \pm 5% (Load)	1k Ω \pm 5% (Resistance to discharge)
SW frequency · Duty · Gate Voltage	80kHz, Duty 50% Vgs=6V	80kHz, Duty 10% Vgs=6V
The number of data	4000 (Teacher 3200/Examination 800)	

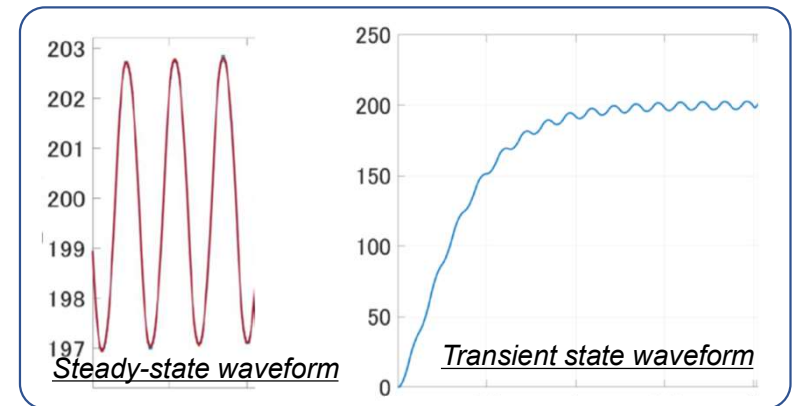

(2) Verification Results (Confusion matrix and reproducibility of the four states)

		Reproducibility				
Truth	C_{out} is abnormal	121	42	34	3	60.5%
	L_{out} is abnormal	13	102	80	5	51.0%
	Normal	35	80	77	7	38.5%
	SW is abnormal	28	83	80	9	4.5%
		C_{out} is abnormal	L_{out} is abnormal	Normal	SW is abnormal	
		Prediction				

(a) Low resolution

Time resolution 80kHz / Voltage resolution 8bit

		Reproducibility				
Truth	C_{out} is abnormal	168		30	2	84%
	L_{out} is abnormal	3	170	26	1	85%
	Normal	51	8	141		70.5%
	SW is abnormal	6	3	14	177	88.5%
		C_{out} is abnormal	L_{out} is abnormal	Normal	SW is abnormal	
		Prediction				

(b) High resolution

Time resolution 800kHz / Voltage resolution 14bit

Figure 1. confusion matrix and reproducibility of the four states (Waveforms of steady state)

		Reproducibility				
Truth	C_{out} is abnormal	194		3	3	97.0%
	L_{out} is abnormal		198	1	1	99.0%
	Normal	7	3	116	74	58.0%
	SW is abnormal	1	1	118	80	40.0%
		C_{out} is abnormal	L_{out} is abnormal	Normal	SW is abnormal	
		Prediction				

(a) Low resolution

Time resolution 80kHz / Voltage resolution 8bit

		Reproducibility				
Truth	C_{out} is abnormal	197		3		98.5%
	L_{out} is abnormal		200			100%
	Normal			157	43	78.5%
	SW is abnormal			33	167	83.5%
		C_{out} is abnormal	L_{out} is abnormal	Normal	SW is abnormal	
		Prediction				

(b) High resolution

Time resolution 800kHz / Voltage resolution 14bit

Figure 2. confusion matrix and reproducibility of the four states (Waveforms of transient states)

Total Reproducibility

$$73.5\% \left(= \frac{194 + 198 + 116 + 80}{200 \times 4} \right)$$

Reproducibility of SW anomaly

$$40\% = \frac{80}{200}$$

*Steady-state waveforms cannot be diagnosed at low resolution.
 *Transient state waveforms can be diagnosed with high accuracy at low resolution for C and L.
 *A method to diagnose SW anomalies at low resolution is needed.

2. Using the machine learning method SVM, the diagnosis of abnormalities in DC/DC converter components is verified by simulation. We propose a method with high discrimination accuracy under low detection resolution conditions.

(1) Verification conditions

- ① Simulation circuit: Same as 1.(1)
- ② Four conditions to diagnose: Same as 1.(1)
- ③ Diagnostic waveform:
Output voltage in transient state
- ④ Other conditions

Vcc	400V±5%
SW1, SW2	GaN HEMT GS66516Bのモデル
Rg	2Ω±5%
Rout	1kΩ±5% (放電抵抗)
ゲート信号	80kHz, Duty10% Vgs=1.5V 固定
分解能毎の 波形の数	4000 (教師3200/試験800)

(2) Verification results (Total reproduction rate for 4 conditions)

	80kHz (1 ^(*2))	160kHz (2)	240kHz (3)	400kHz (5)	800kHz (10)
8bit(391mV ^(*1))	98.8%	99.0%	98.6%	98.4%	99.4%
9bit(195mV)	98.9%	99.4%	99.3%	99.3%	98.1%
10bit(98mV)	99.3%	99.5%	99.6%	99.4%	99.0%
11bit(49mV)	99.8%	99.5%	99.5%	99.8%	99.5%
12bit(24mV)	99.4%	99.5%	99.9%	99.3%	99.3%
13bit(12mV)	99.6%	99.5%	99.5%	99.5%	99.4%
14bit(6mV)	99.8%	99.5%	99.5%	97.6%	99.6%

(*1) Voltage for 1 bit

(*2) Ratio to carrier frequency

*Highly accurate diagnosis is possible by setting the transient state waveform and gate drive voltage to 1.5V (near threshold).